

STF 系列



自封型吸油过滤器

流量 最大1200 L/min



STF自封型吸油过滤器

STF Self-seal Suction Filter

性能参数 Specifications

结构形式: 油箱安装, 自封型	Type of construction: Tank mounted, self-seal
连接形式: BSPP/公制螺纹, SAE法兰	Ports: Threaded BSPP/Metric, SAE flanges
密封材料: 丁晴橡胶, 氟橡胶	Seal material: NBR, Viton, EPDM on request
工作温度: $-30^{\circ}\text{C} \sim +120^{\circ}\text{C}$	Operating temperature range: -30°C to $+120^{\circ}\text{C}$
过滤材料: 滤纸, 金属网	Filtration media: cellulose, wire mesh.
滤芯爆破强度: 1Bar	Element collapse rating: 1 bar (ISO 2941)
旁通阀开启压力: -0.3bar 其它压力按用户需求	Bypass setting: Opening pressure -0.3 bar, Other settings on request.
发讯器报警压力: 真空表, 真空开关 -0.25bar (常开)	Indicator options: Vacuum gauge – vacuum switch -0.25 bar (N.O.)
过滤器壳体材料: 铝	Filter housing: Aluminium head and cover
工作介质相容性: 适用于矿物油, 人工合成油 其它介质咨询公司技术部门。	Fluid compatibility: Suitable for mineral oils, synthetic. For use with water, please contact our company.

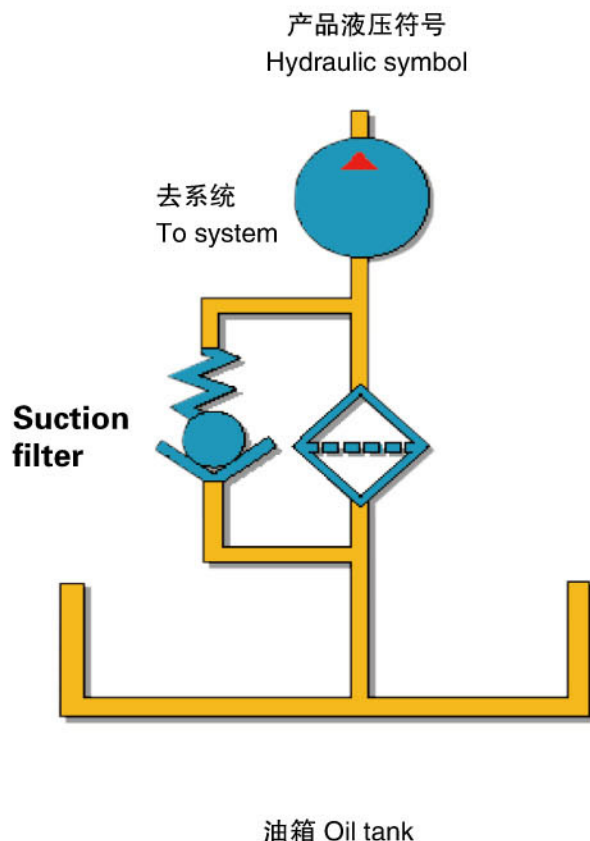

STF自封型吸油过滤器

STF Self-seal Suction Filter

订货代码 Ordering Code

过滤器 The Completed filter

STF 0630 W 100 N B16 V

过滤器型号 Filter type

流量 Flow rate (L/min)

0025, 0040, 0063, 0100, 0160, 0250, 0400
0500, 0630, 0800, 1000, 1200

滤芯材料 Element material

P: 滤纸 Celullose ($\beta x=2$),
W: 金属网 Wire mesh

过滤精度 Filtration rating(μm)

(P): 010, 025 (W): 050 100,150, 180

密封材料 Seals

N:丁晴橡胶 NBR, V: 氟橡胶 Viton

接口法兰形式/尺寸 Port type/Size

流量 Flow Rate	形式/尺寸 Type/Size												
	B(BSP 螺纹thread)				M(公制螺纹Metric thread)				F(法兰Flange)				
	08	12	16	20	24	18	27	33	42	48	40	63	90
STF0025	●					●							
STF0040		●					●						
STF0063			●					●					
STF0100				●					●				
STF0160					●					●	●		
STF0250					●					●	●		
STF0400												●	
STF0500													●
STF0630													●
STF0800													●
STF1000													●
STF1200													●
B08=G ¹ / ₂ , B12=G ³ / ₄ , B16=G16, B20=G1- ¹ / ₄ , B24=G1- ¹ / ₂													
M18=M18x1.5, M27=M27x2, M33=M33x2, M42=M42x2, M48=M48x2													
F40=SAE1- ¹ / ₂ " , F63=SAE2- ¹ / ₂ " , F90=SAE3- ¹ / ₂ "													

发讯器 Indicators

N: 无 NO, V: 真空表 Vacuum gauge, E: 真空开关 Vacuum switch 0.25bar

STF自封型吸油过滤器

STF Self-seal Suction Filter

滤芯 The Replacement Element

STE 0630 W 100 N

滤芯型号 Element type _____

流量 Flow rate (L/min) _____
0025, 0040, 0063, 0100, 0160, 0250, 0400
0500, 0630, 0800, 1000, 1200

滤芯材料 Element material _____
P: 滤纸 Cellulose ($\beta x=2$), W: 金属网 Wire mesh

过滤精度 Filtration rating(μm) _____
(P): 010, 025 (W): 050, 080 100,150, 180

密封材料 Seals _____
N: 丁晴橡胶 NBR, V: 氟橡胶 Viton

过滤器主要参数 Filter Specification

过滤器 Filter	进口 Port	滤芯 Element	重量 Weight(Kg)
STF0025	G1/2, M18x1.5	STE0025...	0.85
STF0040	G3/4, M27x2	STE0040...	0.9
STF0063	G1, M33x2	STE0063...	1.5
STF0100	G1-1/4, M42x2	STE0100...	1.7
STF0160	G1-1/2, M48x2,SAE1-1/2"	STE0160...	2.7
STF0250		STE0250...	4.35
STF0400	SAE2-1/2"	STE0400...	6.15
STF0500	SAE3-1/2"	STE0500...	7.5
STF0630		STE0630...	8.2
STF0800		STE0800...	8.9
STF1000		STE1000...	9.96
STF1200		STE1200...	10.5

压降曲线 Pressure Drop Curves

推荐吸油过滤器初始压降不大于0.03bar。

如果所使用的工作介质粘度不是32cSt，实际压降计算如下：

$$\Delta p = (\Delta p_{32} \times \text{工作介质粘度}) / 32\text{cSt}$$

过滤器压降数据是基于工作介质的动力粘度32cSt、密度0.87得到。

The recommended level of the initial pressure drop for suction filters is max 0.03 bar.

If the medium used has a viscosity different from 32cSt, pressure drop over the filter can be estimated as follows:

$$\Delta p = (\Delta p_{32} \times \text{viscosity of medium used}) / 32\text{cSt}$$

Filter pressure drop based on 32cSt fluid viscosity and 0.87 density.

壳体压降 Filter Housing Pressure Drop

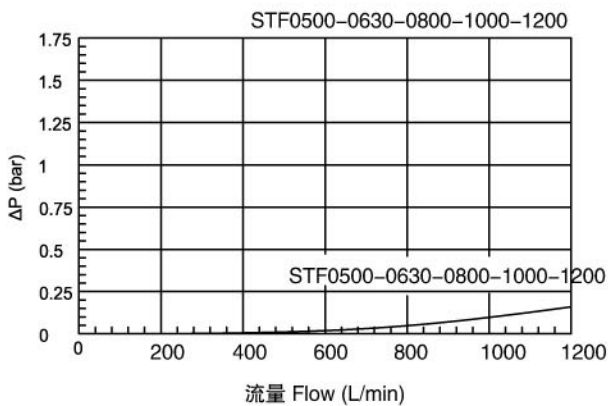
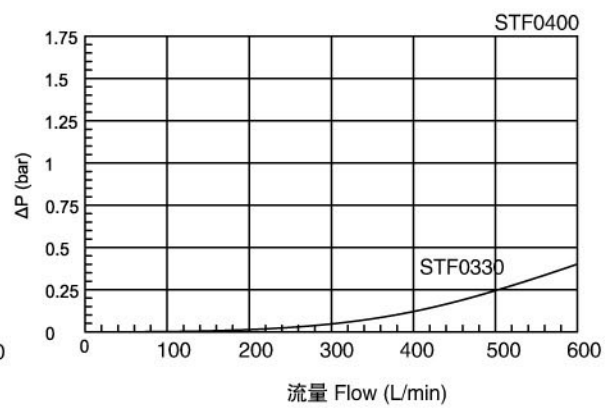
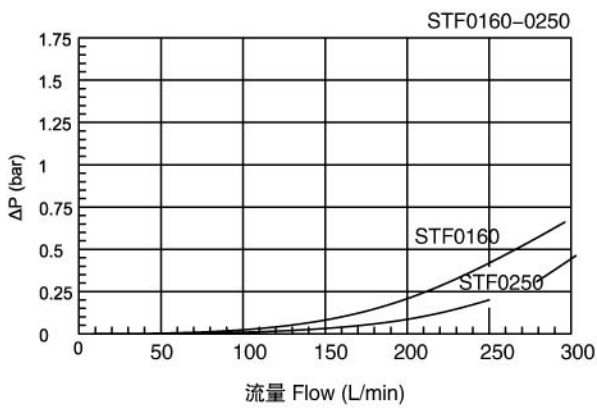
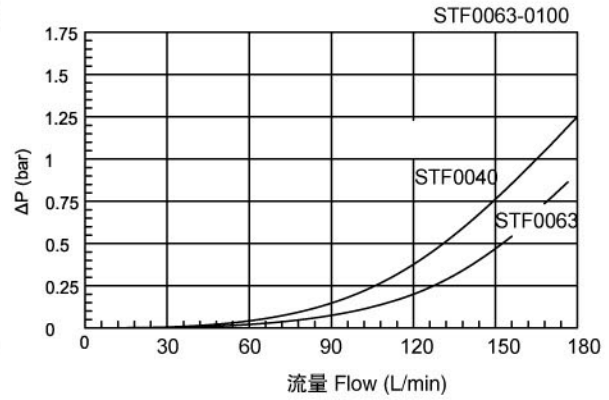
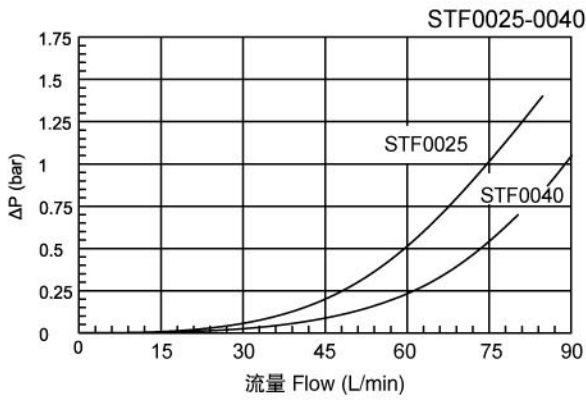

玻纤和滤纸滤芯初始压降

Clean Element Pressure Drop With Media F&P

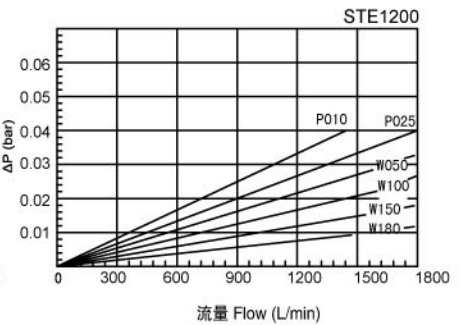
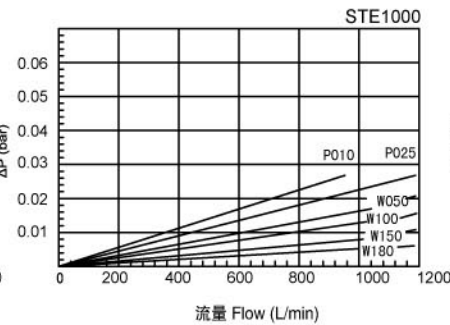
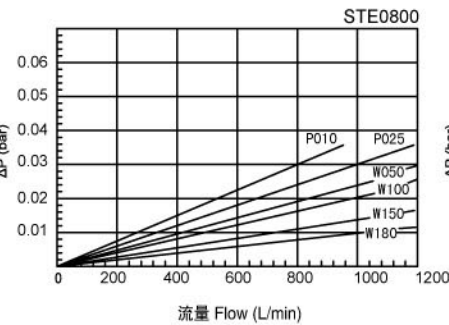
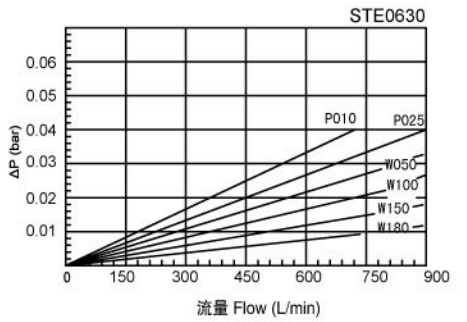
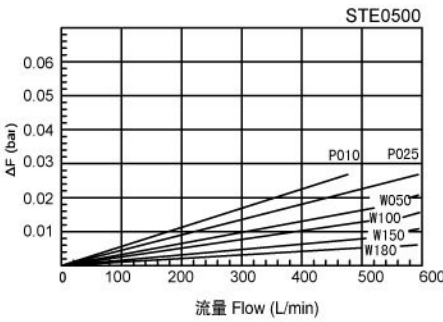
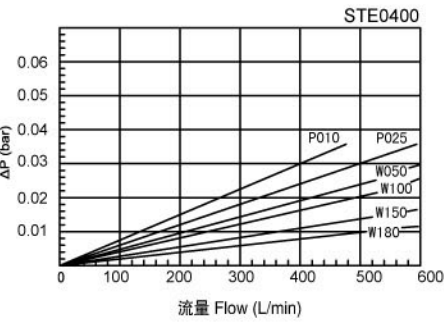
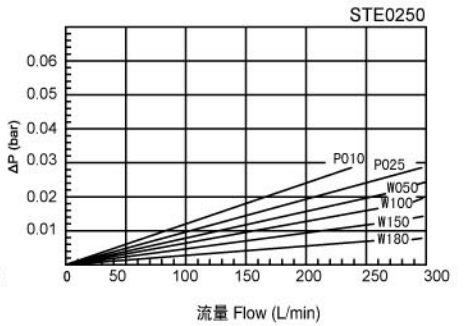
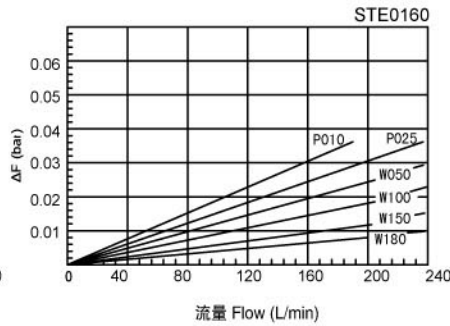
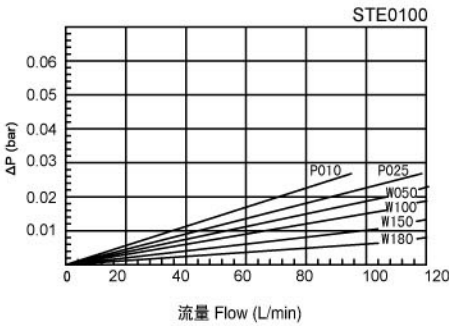
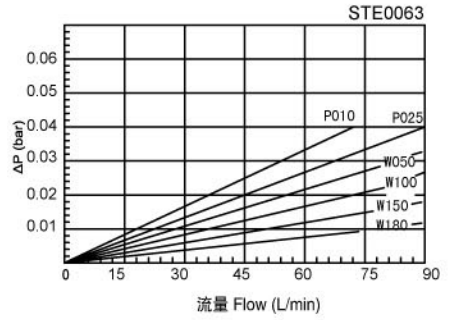
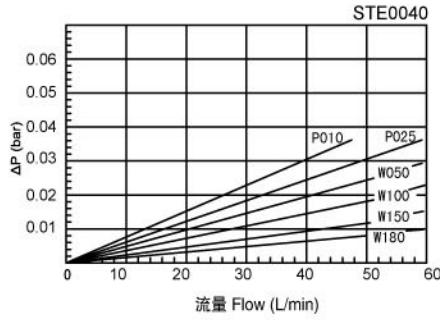
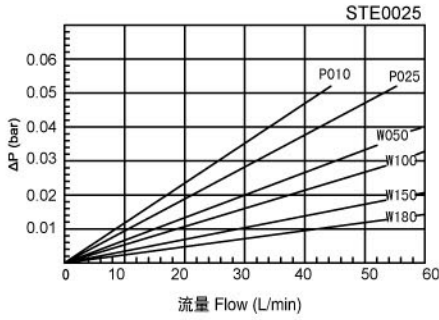

外形安装尺寸 Dimensions

STF0025-0100

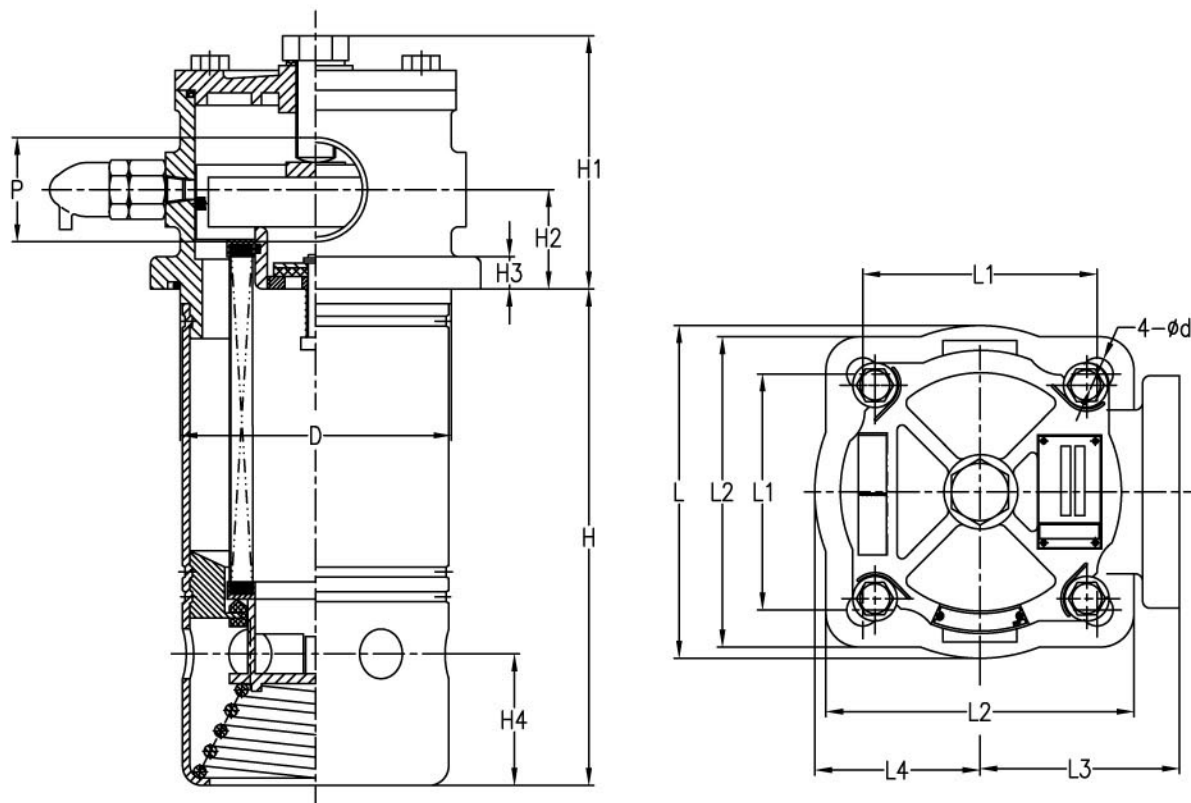

型号 Type	P	D	H	H1	H2	H3	H4	L1	L2	L3	L4	L	d
STF0025	G ^{1/2} ,M18x1.5	φ 75	93	70	25	10	36	70	90	53	45	90	φ 9
STF0040	G ^{3/4} ,M27x2		110										
STF0063	G1,M33x3	φ 95	138	90	33	12	40	85	110	60	53	120	
STF0100	G1- ^{1/4} ,M42x2		188										

STF自封型吸油过滤器

STF Self-seal Suction Filter

外形安装尺寸 Dimensions

STF0160-1200

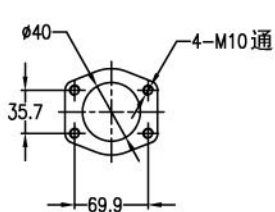
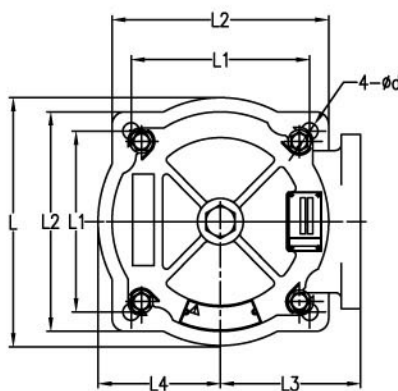
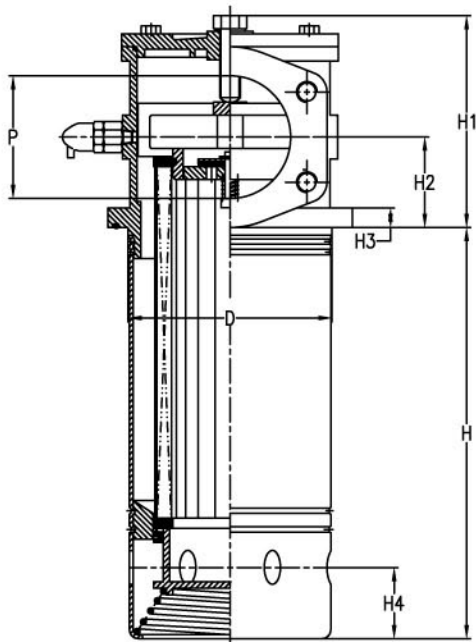

法兰 Flange SAE 1-1/2"

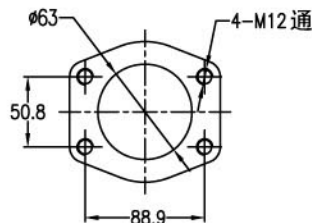

法兰 Flange SAE 2-1/2"

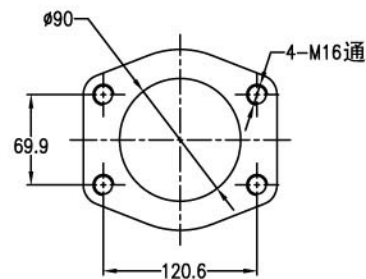

法兰 Flange SAE 3-1/2"

型号 Type	P	D	H	H1	H2	H3	H4	L1	L2	L3	L4	L	d
STF0160	G1-1/2, M48x2, SAE 1-1/2"	φ 110	200	102	40		53	95	125	85	67	134	
STF0250			270										
STF0400	SAE 2-1/2"	φ 130	275	127	55		90	110	140	90	79	159	
STF0500	SAE 3-1/2"	φ 160	319	164	70	15	100	140	170	110	96	192	φ 13
STF0630			385										
STF0800			460										
STF1000			540										
STF1200			700										